

# Movable Party: A bicycle-powered system for interactive musical performance

**Steven Kemper**  
Music Department  
Mason Gross School of the Arts  
Rutgers, The State University of  
New Jersey  
steven.kemper@rutgers.edu

**Josef Taylor**  
josef.taylor@gmail.com

**Wendy F. Hsu**  
ACLS Public Fellow  
City of Los Angeles Department of Cultural  
Affairs  
wendy.f.hsu@gmail.com

**Carey Sargent**  
Scholarship Technology  
Occidental College  
carey.sargent@gmail.com

**Linda Wei**  
where.is.lindawei@gmail.com

## ABSTRACT

Movable Party is a mobile, real-time interactive music system where audience-participants pedal stationary bicycles to generate power and perform interactive music. Inspired by *nakashi* Taiwanese street performance culture, Movable Party creates a bustling public and street-side vibrancy in the decentralized metropolis of Los Angeles. The system consists of three stationary bicycles, each equipped with rear wheel hub motors that generate enough energy to power a medium-sized public address system. The bicycles are also equipped with sensors to track rear wheel speed as well as rider position, transforming them into interactive musical instruments in two different modes: Interactive DJ and Step Sequencer. The Interactive DJ mode enables a laptop performer to create and mix music with data from the three bicycles. The Step Sequencer mode enables rider-participants to directly control a three-voice, eight-step sequencer. Sonic mappings are focused on representation of rear wheel speed, which translates directly to power generation.

## 1. INTRODUCTION

Interactive music systems require human participation, and as such provide an opportunity to invite non-musicians to engage in the process of music making [6]. Novice performers can be encouraged to participate in these systems by converting familiar, everyday actions into musical results. Considering that participants will not have much of an opportunity to learn the system, the user interface must be easy to understand, and mappings must be immediately salient. This may prevent these systems from possessing all of the complexity and expressivity of traditional musical instruments, however striking the right balance between these elements will incentivize continued participation [1].

Embodying this paradigm, Movable Party is a mobile interactive music system where audience-participants pedal stationary bicycles to generate power and perform interactive music (see Figure 1). Created for pop-up performances on the streets of Los Angeles, Movable Party highlights themes of community engagement and sustain-

Copyright: © 2014 Steven Kemper et al. This is an open-access article distributed under the terms of the [Creative Commons Attribution License 3.0 Unported](#), which permits unrestricted use, distribution, and reproduction in any medium, provided the original author and source are credited.

able energy by sonically mapping power generation to musical outcomes. The project is inspired by *nakashi*, an itinerant musical practice rooted in postcolonial street culture in Taiwan [9,11]. Created by the Movable Parts collective, Movable Party was completed in collaboration with students from Occidental College and members of Los Angeles based community arts and bicycling groups.

The Movable Party system consists of three bicycles fixed on trainers, each equipped with a hub motor, sensors, and Arduino microcontroller. The system can generate enough power to continuously run a medium-sized (300W) public address (P.A.) system. This allows for amplified musical performances without the need for external power. Sensor data from the bicycles is mapped to musical parameters of sound generation and processing in two modes: Interactive DJ and Step Sequencer. The Interactive DJ mode enables a laptop performer to use data streams from the bicycles to control and process soundfile playback and synthesis. The Step Sequencer mode enables rider-participants to directly control a three-voice, eight-step sequencer. Both modes feature the sonification of rear wheel speed, providing riders with acoustic feedback on the amount of power they are generating in real time. Since sound is only produced when riders are pedaling, Movable Party actively encourages participants to engage in the processes of music making and power generation.



**Figure 1:** Movable Party in Performance.

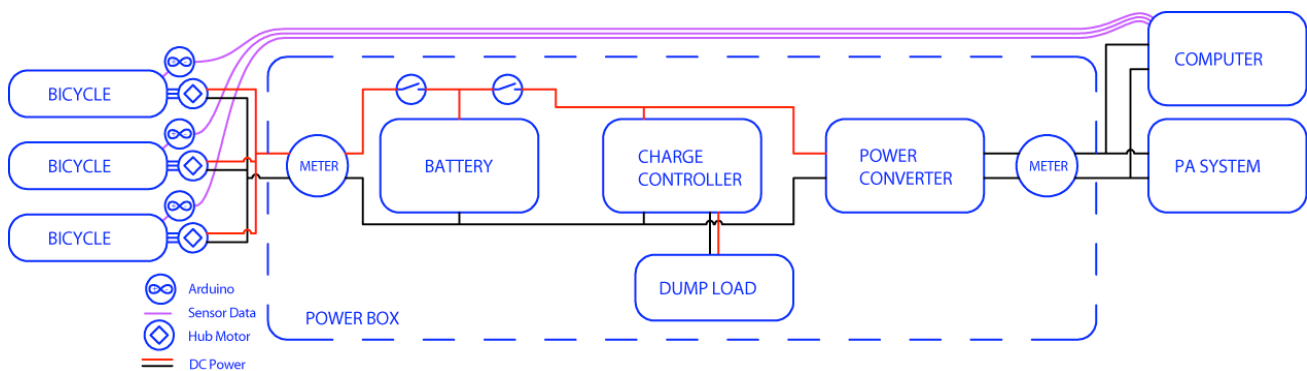

Figure 2: System design.

## 2. RELATED WORK

Adapting the spatial fluidity and “low-tech” innovations of Taiwan’s nakashi street culture, Movable Party was conceived of as a way to create a bustling public and street-side vibrancy, with a focus on sustainable energy, in the decentralized metropolis of Los Angeles. Brought from Japan during the colonial era in Taiwan, nakashi in its original Japanese “Nagashi” (流し), meaning “flow,” refers to a flexible mode of performance. Nakashi musicians amplify instruments such as the guitar and accordion through loudspeakers to make ad hoc performances, traditionally in tea parlors and hot springs resorts throughout Taiwan [11]. Over time, nakashi performers innovated their practice by turning toward streets and public spaces including parks and temple plazas, constructing mobile and self-powered performance platforms. Movable Party extends this tradition by inviting members of the public to participate in the musical performance.

Movable Party’s power generation technology is based on a bicycle-powered generator designed for the 2011 Seattle Bicycle Music Festival [7], which itself was a version of Rock the Bike’s commercially available pedal-powered system [4]. Movable Party extends the power generation capability of these systems by turning the bicycles into interactive musical instruments.

Other interactive bicycle projects include the Turntable Rider by the Japanese bike-sharing service Cogoo [2] and Andrew Nagata’s Two Wheel Dissonance [5]. As a novel interactive instrument Movable Party differs from these systems in a few ways. First, Movable Party is a participatory system, where riders take turns pedaling in order to generate power and make music. The entire system is stationary, which allows the direct mapping of rear wheel speed to musical parameters, without having to maintain a minimum speed to keep the bicycle upright. The method of mapping rotational data from a wheel to musical parameters is similar to the Gyrotyre [8], however the ability to control the speed of the wheel through pedal power creates a much stronger relationship between physical gesture and sound production. This allows participants to create music using familiar actions, as opposed to the Gyrotyre, which is handheld and performed more like a traditional musical instrument.

## 3. SYSTEM DESIGN

The Movable Party system is designed to both generate power and provide rider interaction data, including rear wheel speed and rider position. In order to capture generated power, hub motors attached to the rear wheel of each bicycle are connected in parallel to a charge controller and a 24V battery. A power converter converts the power stored in the battery to 120V AC. The charge controller, battery, and power converter are housed in a separate “power box” that is connected to all three bicycles. The power generated by this system is used to power a stereo P.A., a computer running Max, and a USB hub that powers the Arduino microcontrollers (see Figure 2). To ensure the system is generating enough power, both the voltage generated by the bicycles as well as wattage coming from the power converter are monitored.



Figure 3: Sensor/Arduino configuration.

Three sensors on each bicycle provide data for interactive musical performance: the Hall effect sensor in the rear wheel hub motor and two force sensing resistors (FSRs), one under the right handlebar grip and one on the saddle (see Figure 3). Sensor data is collected using an Arduino Uno microcontroller and transmitted via USB to a computer running Max. The Arduino converts Hall effect sensor data to revolutions per minute (RPM). Rising voltage from the Hall effect sensors triggers a hardware interrupt that keeps track of the number of wheel revolutions. This data is passed to the loop() function, where the number of interrupts is divided by elapsed time in milliseconds and converted to minutes. If there are no Hall effect sensor triggers after a fixed period of time (3 se-

conds), the Arduino will send out an RPM value of -1, indicating that the wheel has stopped.

The handlebar grip and saddle FSRs are used to collect data about rider position, for example whether the rider is sitting or standing, as well as provide the rider direct control over sound generation and processing. Data from the FSRs is read into analog inputs on the Arduino, and packaged with the RPM data as serial output to Max. The serial communication protocol is based on the Serial Call-Response code created by Scott Fitzgerald and Tom Igoe [3].

### 4. IMPLEMENTATION

Movable Party enables two different modes of interactive performance: Interactive DJ and Step Sequencer, both created in Max. The Interactive DJ mode enables a “trained” laptop performer to create and mix music with data from the three bicycles. In this mode, the laptop performer (who is not a rider) controls how data is mapped and is responsible for the final musical output. In contrast to this centralized control model, the Step Sequencer mode provides rider-participants direct control over the musical output.

Both modes feature the musical mapping of RPM data from the rear wheel. Though rider-participants are free to pedal at whatever speed they wish, most riders pedal at a consistent speed. This posed the challenge of how to produce interesting musical results with consistent data, necessitating a different paradigm from non-stationary systems such as the Turntable Rider [2]. The mappings of RPM data are designed to provide auditory feedback to riders about their current speed, as well as to incentivize them to pedal at a fast enough rate to provide power to the system [10].

#### 4.1 Interactive DJ

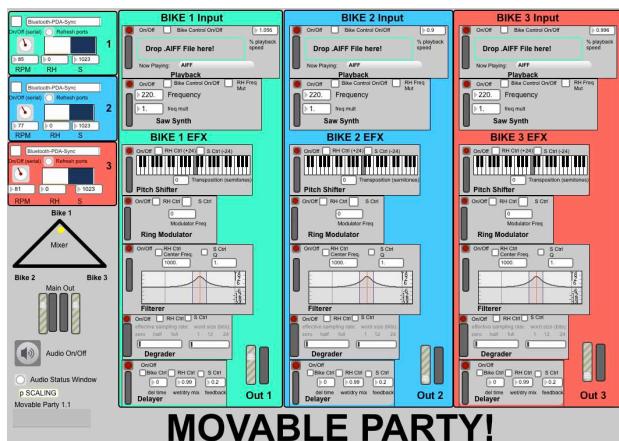

Figure 4: Interactive DJ Max Interface.

The Interactive DJ mode allows a laptop performer to mix three channels of audio using sensor data from the bicycles for both sound generation and processing (see Figure 4). Each channel is associated with a specific bicycle, and contains a sound generator and effects processing module. The laptop performer may select either a sound file or synthesis as the sound generator for each channel. RPM data from the Hall

effect sensors is mapped to either playback speed in the case of sound file playback, or the frequency of a sawtooth wave oscillator in the case of synthesis. The handlebar grip and saddle FSRs are used to control different effects parameters. The DJ can turn the sensor data on or off for each module, and the scaling of each parameter can be manually adjusted from its preset range. Additionally, a three-channel mixer allows the DJ to fade between the signals being generated/processed by each bicycle. See Table 1 for a complete list of mappings.

Module	Sensor Data	Musical Parameter	Mappings
Playback	RPM	% of playback speed	84 RPM = 1 x playback speed
Saw Synth	RPM	Frequency	RPM = frequency
	Hand grip FSR	Frequency multiplier	1-6 x frequency
Pitch Shifter	Hand grip FSR	Transposition (positive)	0-24 semi-tones above original pitch
	Saddle FSR	Transposition (negative)	0-24 semi-tones below original pitch
Ring Modulator	Hand grip FSR	Modulator frequency	0-200Hz modulating frequency
	Saddle FSR		
Filterer	Hand grip FSR	Band-pass filter center frequency	30-10,000Hz
	Saddle FSR	Band-pass filter Q factor	0.2-5 Q
Degrader	Hand grip FSR	Resampling frequency ratio	0.05-1Hz resampling frequency
	Saddle FSR	Bit depth	3-16 bit depth
Delayer	RPM	Delay time	RPM of 0-120 mapped to 500-10 ms
	Hand grip FSR	Wet/Dry mix	0-1 (0=dry, 1=wet)
	Saddle FSR	Feedback %	0-0.95 %

Table 1: Interactive DJ Sensor Mappings.

In performance, riders achieved an average speed between 70-90 RPM. For sound file playback, 84 RPM is mapped to normal playback speed. This incentivizes riders to maintain a consistent speed, as acceleration/deceleration would continuously alter the speed of sound file playback. While some riders played with the effect of rapidly changing speed, most chose to maintain



a consistent pace that produced close to original playback speed.

In the case of synthesis, RPM data is mapped directly to frequency and the handlebar grip FSRs control a frequency multiplier. The synthesis performance mode leaves control of sound generation to riders, with the DJ controlling the mix between each channel as well as effects processing. In performance the synthesis mode produced a “noisier,” more experimental texture. Riders were more likely to rapidly change the rate at which they were pedaling, as well as to try and match the pedaling speed of their fellow riders in order to match pitch.

### 4.2 Step Sequencer

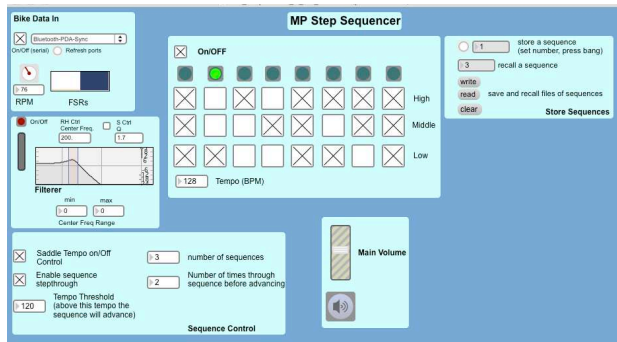

Figure 5: Step Sequencer Max Interface.

The Step Sequencer mode, which was developed after the initial deployment of the system, allows riders direct control of the musical output (see Figure 5). The sequencer consists of a three-voice, eight-step grid, with a sound palette that is evocative of early drum machines such as the Roland TR-808. The voices are made from synthesized tones in low, middle, and high frequency ranges. In performance each bicycle controls its own sequencer. The use of this limited sonic material allows riders to easily hear how the data from their bicycle affects the musical texture.

The tempo of the triggering pulse (BPM) is controlled by RPM data coming from the bicycle. RPM also controls the pitch (frequency) of the high voice, so as the tempo increases, so does the pitch of this voice. The saddle FSR is used to detect if the rider is seated on bike or not. If the rider stands up, the sequence will stop, allowing the rider to choreograph breaks. The filtering module from the Interactive DJ mode has been included to give the rider greater control over the sonic output. For a complete list of mappings, see Table 2.

High voice	RPM	Pitch	RPM of 0-120 mapped to 400-1800 Hz
Filterer	Hand grip FSR	Band-pass filter center frequency	200-1,000Hz
	Saddle FSR	Band-pass filter Q factor	0.2-4 Q

Table 2: Step Sequencer Sensor Mappings

By pedaling fast enough, riders step through a preprogrammed series of sequences. In order to reach the next sequence, the rider must maintain BPM (tempo) above a set threshold for a certain number of repetitions. This threshold is initially set to 120 BPM (69 RPM), however it is adjustable. If the rider slows down and BPM falls below this threshold, the sequencer will return to the first sequence. By programming in sequences of increasing complexity, the Step Sequencer becomes a musical challenge to the rider: maintain the tempo above a certain threshold and get “rewarded” by reaching a more complex musical outcome.

### 4.3 Movable Party in Performance

Movable Party premiered in April 2013 at CicLAvia, a bi-yearly event that closes the streets of Downtown L.A. to vehicular traffic, attracting over 150,000 participants.<sup>1</sup> The system was set up in a prominent position in front of MacArthur Park, drawing a steady flow of participants throughout the day.

Overall, participants preferred the Interactive DJ synthesis mode, while audience members preferred the sound file playback mode. The synthesis mode made it easier for participants to hear how their pedaling directly impacted the music. Providing participants greater control over the sound forced them to be more attentive to their movements, which required greater concentration. Therefore this mode was best deployed for short periods of time (< 5 min.).

The conflict between what was sonically interesting for the audience and for participants reflects an inherent challenge in public performances where participation is limited to a few people at a time. Since CicLAvia, Movable Party has been deployed in a variety of formal and informal contexts, with the addition of the Step Sequencer mode. Though initially designed for public performances by novices with no previous experience with the system, the most compelling performance to date came from a late-night impromptu jam session at the Knowhow Shop, a Northeast L.A. fabrication/design shop. This performance featured the Interactive DJ Synthesis mode, and a small group of riders performed on the system long enough to master the expressive potential of the system.

Module	Sensor Data	Musical Parameter	Mappings
Sequencer	RPM	Tempo	RPM of 0-120 mapped to 40-180 BPM
	Saddle FSR	Start/Stop sequence	Standing up stops sequence, sitting down starts sequence

<sup>1</sup> <http://www.ciclavia.org/>

## 5. PERFORMANCE ISSUES

Both the Interactive DJ and Step Sequencer modes were successful in allowing the general public to engage in music making, though there are a few areas of design that could be improved. Adding an external MIDI controller to the Interactive DJ mode would enable the laptop performer more fluid control over the Max patch. Also, the Interactive DJ software requires a trained performer, so only those collaborators who were familiar with the system could use it successfully. The Step Sequencer mode, on the other hand, was easily taught to members of the public.

Visual display of power generation could also be improved. Currently, information on power generation from each bicycle and the voltage level of the battery is available on a small display located on the power box, however providing a visual display of each rider's real-time power generation would help attract participants and better educate the public about the amount of energy being generated and consumed. It would provide a visual cue to audience members as to how riders were affecting the sound.

The biggest technical issue encountered is that at certain times power generation causes interference with the data coming from the hub motor Hall effect sensors. This issue is particularly pronounced when high voltage spikes occur due to fast pedaling from a standstill. After consultation with the manufacturer, it was determined that the Hall effect sensor output needs to be isolated from the rest of the system, using an RC filter with hysteresis.

## 6. CONCLUSION AND FUTURE WORK

In the future we will work on creating a better visual experience for rider-participants and the audience, and allow more flexibility in interfacing with DJs using a variety of software. In order to provide riders with a more engaging experience, we plan on developing a tablet-based GUI that displays information on the power they are currently producing, remaining battery power, and allows them to change parameters of the Interactive DJ and Step Sequencer modes to allow greater control over their own performance. We will also adopt the MIDI protocol for sensor data coming from the bikes. This will allow DJs to use software of their choice to integrate data from the bikes into their performances. Finally, we will develop displays for the audience that indicate power generation for each bike, rider speed, and a visualization of the music being produced that shows the link between power generation and sonic output.

### Acknowledgments

Movable Party was made possible through support from the ASOC Renewable Energy & Sustainability Fund, Center for Digital Learning + Research at Occidental College, CicLAvia, Flying Pigeon, Bike Oven, and the Knowhow Shop.

## 7. REFERENCES

- [1] T. Blaine, T. and S. Fels, "Contexts of Collaborative Musical Experiences" in *Proceedings of the 2003*

*Conference on New Interfaces for Musical Expression*, Montreal, 2003, pp. 129–134.

- [2] Cogoo. Turntable Rider. <https://cogoo.jp/turtabletrider>. Accessed 1/14/2014.
- [3] S. Fitzgerald and T. Igoe, Serial Call-Response. <http://arduino.cc/en/Tutorial/SerialCallResponse>. 2009, rev. 2012. Accessed 12/20/2013.
- [4] P. Freedman, Pedal-Powered Music. Ted@Vancouver (video). <http://talentsearch.ted.com/video/Paul-Freedman-Pedal-powered-mus;TEDVancouver>. Accessed 1/17/2014.
- [5] A. Nagata, Two Wheel Dissonance. <http://cargocollective.com/andrewnagata/Two-Wheel-Dissonance>. Accessed 1/6/2014.
- [6] R. Rowe, "Aesthetics of Interactive Music Systems." *Contemporary Music Review* vol. 18 no. 3 pp. 83-87, 1999.
- [7] Seattle Bicycle Music Project. <http://www.seattlebicyclemusicfestival.com>. Accessed 1/17/2014.
- [8] E. Sinyor and M. Wanderley, "Gyrotyre: A dynamic hand-held computer-music controller based on a spinning wheel." in *Proceedings of the 2005 Conference on New Interfaces for Musical Expression*, Vancouver, 2005, pp. 42-45.
- [9] J. E. Taylor, "Popular music as postcolonial nostalgia in Taiwan." in *Refashioning Pop Music in Asia: Cosmopolitan Flows, Political Tempos, and Aesthetic Industries*, ed. A. Chun et. al., Eds. New York, NY: RoutledgeCurzon, 2004, pp. 173-182.
- [10] B. Vlist et. al. "moBeat: Using Interactive Music to Guide and Motivate Users During Aerobic Exercising." in *Applied Psychophysiology and Biofeedback* vol. 36 no. 2 pp. 135-145, 2011.
- [11] Wang, X. Yi "Nakaxi Wei Hexin Kan Beitou Wenquan Wenhua Bianqen. 以那卡西為核心看北投溫泉文化變遷 (Nakashi as a Lens to Study the Transformation of Beitou Hot Springs Culture)." MA thesis, National Taiwan Normal University, Taiwan, 2011.